

PART-1 GENERAL

1.01 DESCRIPTION

- A. Particle board core compartment work includes the following:
 - 1. Floor anchored partitions.
- B. Furnish all labor and materials necessary for the completion of work in this section as shown on the contract drawings and specified herein.
- C. Work in this section shall include but is not limited to:
 - 1. Toilet compartments
 - 2. Hardware for toilet compartments
 - 3. Shop drawings and working drawings
 - 4. Manufacturer's guarantee
- D. Related work specified elsewhere shall include accessories and anchorage/blocking for attachment of compartments.

1.02 PRODUCTS

- A. Submittal of shop drawings and details, for architects approval.
- B. Colors shall be selected from the manufacturer's standard range of colors.
- C. Color and hardware samples shall be submitted for approval to the architect upon request.

PART-2 PRODUCTS

2.01 MANUFACTURER

- A. Toilet compartments to be supplied by Global Partitions, Eastanollee, GA 30538.

2.02 MATERIALS

- A. Doors and panels shall be 1" thick, constructed of decorative plastic laminate, bonded with a non-toxic adhesive under pressure to a 7/8" particle board core; the laminate to be 0.050" with a matte finish; the core to be 45-pound density, resin impregnated particle board.
- B. Pilasters shall be 1-1/4" thick, constructed of decorative plastic laminate, bonded with a non-toxic adhesive under pressure to a 1-1/8" particle board core; the laminate to be 0.050" with a matte finish; the core to be 45-pound density, resin impregnated particle board.

2.03 CONSTRUCTION

- A. Door and panel finished thickness to be 1". All face and edge surfaces to be covered with decorative laminate, face surfaces to overlap all edges so that joints between laminates fall on the edge surface of components only. Doors to be recessed to accept hinges within the door and yield bi-directional operation about an axis within the plane of the door.
- B. Pilasters finished thickness to be 1-1/4". All face and edge surfaces to be covered with decorative laminate, face surfaces to overlap all edges so that joints between laminates fall on the edge surface of components only. Pilasters shall include a mounting system comprising a 3/8" x 1" steel bar attached to the pilaster in a GLOBAL PLUG LOC arrangement having 3/8" steel bolts secured to 1/8" semi-cylindrical nuts imbedded within a contoured aperture transversely piercing the core at least 1" above the mounting end. Each mounting bar shall be secured to the building structure with 3/8" cadmium-plated studs. A shoe shall conceal each floor mounting, having an internal cross section conforming to the pilaster, and being formed of type 304 stainless steel #4 finish.
- C. The color and texture of the finish on plastic laminate units is determined by the selected decorative pattern.

2.04 HARDWARE (NOTE: Refer to the ORDER INFORMATION CONTRACT for specific hardware to be supplied on your order.)

- A. All exposed door hardware shall be of chromium-plated diecast Zamac and shall be as noted:
 - 1. Upper and lower door hinge is recessed within the plane of the door and saddled on the adjacent pilaster, to yield bi-directional operation about an axis within the plane of the door. All hinges to include adjustable cams to support the door and establish quiescent positions by gravity only.
 - 2. Slide latches shall be mounted at the mid-point of the door, 29" up from the bottom. Keepers shall be designed and installed permitting emergency access to the compartment by lifting the door until the latch bolt is clear of the keeper.
 - 3. Hardware includes coat hook, bumper, stop, keeper and all necessary fasteners for installation.
- B. Fasteners shall be of chrome-plated steel; door hinges will be mounted with tamper resistant barrel nuts and machine screws; hooks and handles will be mounted with tamper resistant full-thread screws.
- C. Wall brackets shall be secured to walls with anchoring and/or expansion shields.
- D. Pilaster shoes shall be of type 304 stainless steel #4 finish.

PART-3 EXECUTION

3.01 PREPARATION

- A. Examine areas to receive toilet compartments for correct height and spacing of anchorage/blocking and plumbing fixtures that may affect installation of compartments. Report any discrepancies to the architect.
- B. Take complete and accurate measurements of complete toilet compartment locations.
- C. Start of work constitutes acceptance of job.

3.02 INSTALLATION

- A. Install compartments in a rigid, straight, plumb and level manner as shown on the shop drawings and manufacturer's installation instructions.
- B. All doors and panels to be mounted at 12" above the finished floor.
- C. Clearance at vertical edges of door shall be uniform top to bottom.
- D. No evidence of cutting, drilling and/or patching shall be visible on the finished work.
- E. Finished surfaces shall be cleaned after installation and be left free of all imperfections.

3.03 WARRANTY

- A. Global Partitions guarantees its plastic laminated units, properly maintained, against discoloration or delamination for 2 years from the date of receipt by the customer. If materials are found defective during that period for the reasons listed above, the material will be replaced free of charge. No credits or allowances will be issued for any labor or expenses relating to the replacement of components covered under the warranty plan. All such expenses are to be borne by the buyer.

4.03

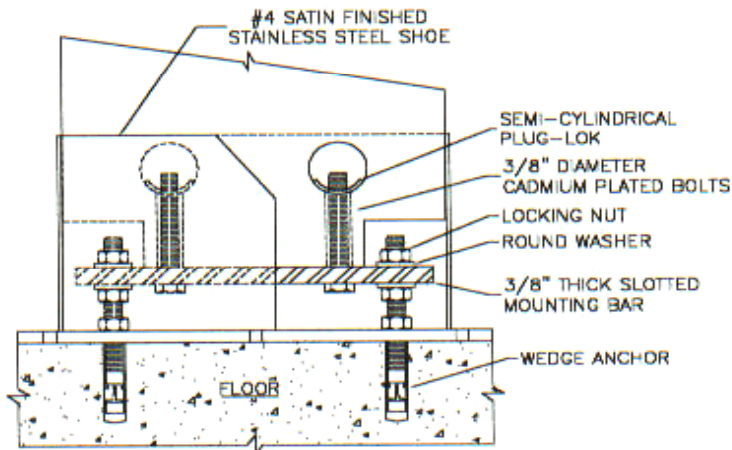
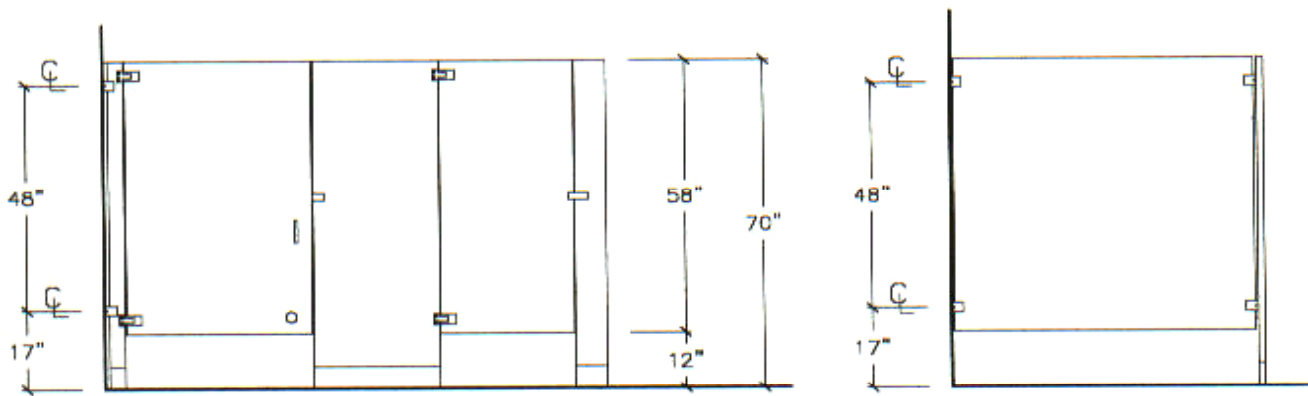

FLOOR ANCHORING DETAIL

