

1.01 DESCRIPTION

- A. Solid plastic (polymer) work includes the following:
 - 1. Wall anchored vanities
- B. Furnish all labor and materials necessary for the completion of work in this section as shown on the contract drawings and specified herein.
- C. Work in this section shall include, but is not limited to:
 - 1. Vanities.
 - 2. Hardware for vanities.
 - 3. Shop drawings and working drawings.
 - 4. Manufacturer's guarantee.
- D. Related work specified elsewhere shall include accessories and anchorage/blocking for attachment of vanities.

1.02 PRODUCTS

- A. Submit six sets of shop drawings and details for architect's approval
- B. Color shall be selected from the manufacturer's standard range of colors:
- C. Color and hardware samples shall be submitted for approval to the architect upon request.

PART-2 PRODUCTS

2.01 MANUFACTURER

- A. Solid plastic (polymer) vanities to be supplied by Global Partitions, Eastanollee, Georgia, 30538.

2.02 MATERIALS

- A. Vanity, back splash, side splash, apron and support shall be 1" thick, with homogeneous color throughout, constructed from high-density polyethylene (HDPE) resins, which are, waterproof non-absorbent and have a self-lubricating surface that resists markings from pens, pencils and other writing instruments.

2.03 CONSTRUCTION

- A. Vanity top shall be 1" thick with a standard width of 24" with a maximum length of 120" for single piece. Apron, back splash and side splash shall be a standard height of 4" and have a maximum length of 120" and shall be 1" thick with uniformly machined edges.

2.04 HARDWARE

- A. Vanity hardware shall be as noted:
 - 1. Solid plastic (polymer) vanity supports shall be supplied and evenly spaced a maximum of every 36".
 - 2. The vanity top and supports shall be secured to each other and to adjacent wall construction by means of a 2" x 2" x 18" long anodized aluminum angle bracket. All brackets are mounted with stainless steel tamper resistant screws.

PART-3 EXECUTION

3.01 PREPARATION

- A. Examine areas to receive vanities for correct height and spacing of anchorage/blocking and plumbing fixtures that may affect installation of vanities. Report any discrepancies to the architect.
- B. Take complete and accurate measurements of complete vanity locations.
- C. Start of work constitutes acceptance of job.

3.02 INSTALLATION

- A. Install vanities in a rigid, straight, plumb and level manner, in accordance with the shop drawings and manufacturer's installation instructions.
- B. No evidence of cutting, drilling and/or patching shall be visible on the finished work.
- C. Finished surfaces shall be cleaned after installation and be left free of all imperfections.

3.03 WARRANTY

- A. GLOBAL Steel Products Corp. guarantees its plastic against breakage, corrosion and delamination for 15 years from the date of receipt by the customer. If materials are found defective during that period for the reasons listed above, the materials will be replaced free of charge. No credits or allowances will be issued for any labor or expenses relating to the replacement of components covered under the warranty plan. All such expenses are to be borne by the buyer.

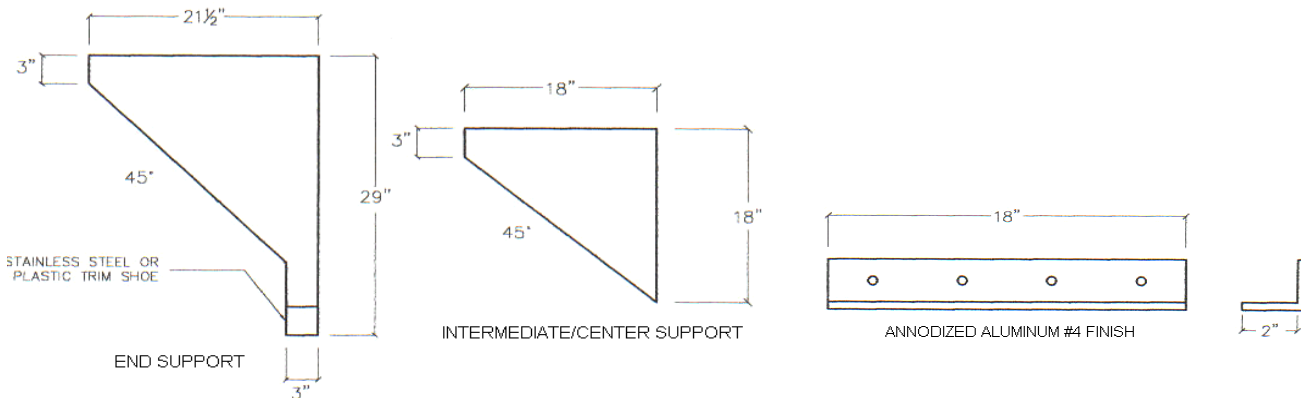
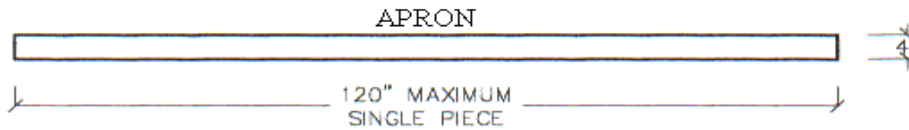
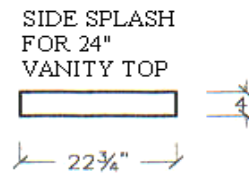
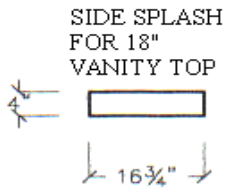
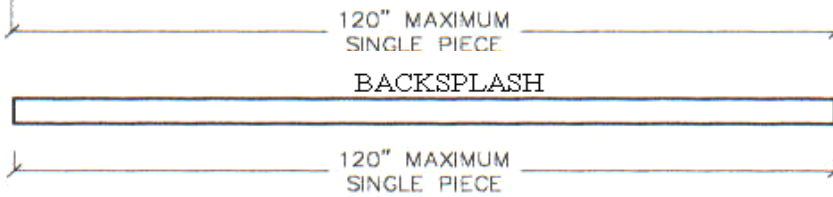
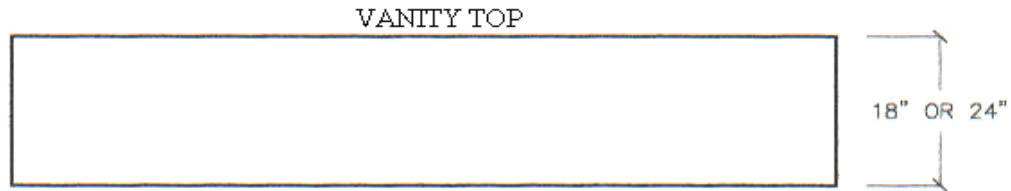
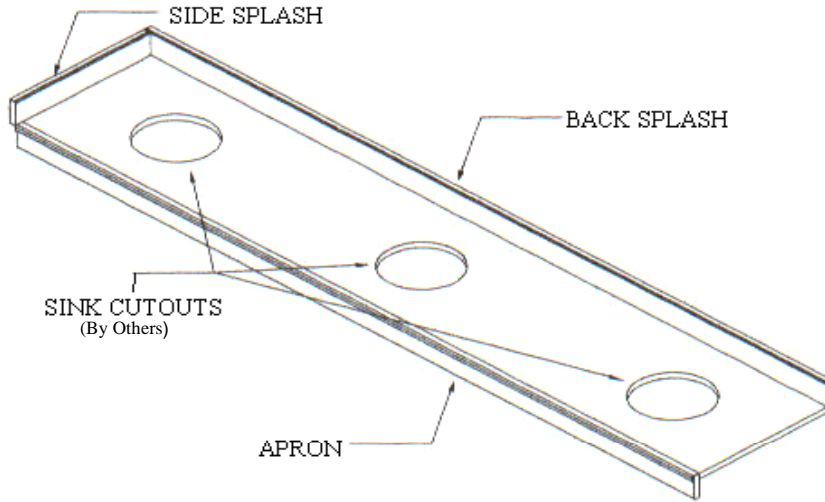

END SUPPORT AND INTERMEDIATE/CENTER SUPPORT ARE BOTH 1" THICK HDPE.
INTERMEDIATE/END SUPPORT SHALL BE EVENLY SPACED AT A MAXIMUM OF 36".

NOT TO SCALE