

PART-1 GENERAL

1.01 DESCRIPTION

- A. Phenolic compartment work includes the following:
- B. Floor and ceiling anchored partitions.
- C. Furnish all labor and materials necessary for the completion of work in this section as shown on the contract drawings and specified herein.
- D. Work in this section shall include but is not limited to:
 - 1. Toilet compartments
 - 2. Hardware for toilet compartments
 - 3. Shop drawings and working drawings
 - 4. Manufacturer's guarantee
- E. Related work specified elsewhere shall include accessories and anchorage/blocking for attachment of compartments.

1.02 PRODUCTS

- A. Submittal of shop drawings and details, for architects approval.
- B. Colors shall be selected from the manufacturer's standard range of color-thru colors.
- C. Color and hardware samples shall be submitted for approval to the architect upon request.

PARTITIONS

**MAXIMUM CEILING HEIGHT 9'-0"
MINIMUM CEILING HEIGHT 7'-6"**

PART-2 PRODUCTS

2.01 MANUFACTURER

- A. Toilet compartments to be supplied by Global Partitions, Eastanollee, GA 30538.

2.02 MATERIALS

- A. Doors shall be constructed of ¾" solid phenolic core decorative plastic laminate with multiple resin-impregnated kraft and surface sheets fused at high temperature and pressure. Phenolic core color shall be the same as the decorative surface sheets.
- B. Panels shall be constructed of ½" solid phenolic core decorative plastic laminate with multiple resin-impregnated kraft and surface sheets fused at high temperature and pressure. Phenolic core color shall be the same as the decorative surface sheets.
- C. Pilasters shall be constructed of ¾" solid phenolic core decorative plastic laminate with multiple resin-impregnated kraft and surface sheets fused at high temperature and pressure. Phenolic core color shall be the same as the decorative surface sheets.

2.03 CONSTRUCTION

- A. Doors shall be constructed of ¾" solid color-thru phenolic core decorative plastic laminate with multiple resin-impregnated kraft and surface sheets fused at high temperature and pressure; the edges being finished and polished.
- B. Panels shall be constructed of ½" solid color-thru phenolic core decorative plastic laminate with multiple resin-impregnated kraft and surface sheets fused at high temperature and pressure; the edges being finished and polished.
- C. Pilasters shall be constructed of ¾" solid color-thru phenolic core decorative plastic laminate with multiple resin-impregnated kraft and surface sheets fused at high temperature and pressure; the edges being finished and polished. Pilasters shall include a mounting system comprising a 3/8" x 1" steel bar attached to the pilaster in a Global Plug Loc arrangement having 3/8" cadmium-plated bolts secured to 1/8" semi-cylindrical nuts imbedded within a contoured aperture transversely piercing the core at least 1" above the mounting end. Each mounting bar shall be secured to the building structure with 3/8" cadmium-plated studs. A shoe shall conceal each floor and ceiling mounting.

2.04 HARDWARE (NOTE: Refer to the ORDER INFORMATION CONTRACT for specific hardware to be supplied on your order.)

- A. All exposed door hardware shall be of chromium-plated diecast Zamac and shall be as noted:
 - 1. Heavy-duty "Bank Vault" hinge shall have gravity-acting cams and are fabricated from a die cast aluminum alloy with a brushed polish chrome-plated finish and wraparound flanges. The cam is constructed from a ¾" diameter nylon rod and a 3/8" stainless steel pin. Hinges are through-bolted onto doors and pilasters using stainless steel tamper resistant through bolts. Hinges are easily adjusted at the job site to a full close or partially open position, as required.
 - 2. Slide latches shall be mounted at the mid-point of the door, 29" up from the bottom. Keepers shall be designed and installed permitting emergency access to the compartment by lifting the door until the latch bolt is clear of the keeper.
 - 3. Hardware includes coat hook, bumper, stop, keeper and all necessary fasteners for installation.
- B. Fasteners shall be of stainless steel; door hinges and latches will be mounted with tamper resistant barrel nuts and machine screws; hooks and handles will be mounted with tamper resistant, full-thread screws.
- C. Wall brackets shall be secured to walls with anchoring and/or expansion shields.
- D. Pilaster shoes shall be of type 304 steel #4 finish.
- E. All mounting brackets shall be cast stainless steel. All material shall be through-bolted with stainless steel tamper-resistant fasteners.

PART-3 EXECUTION

3.01 PREPARATION

- A. Examine areas to receive toilet compartments for correct height and spacing of anchorage/blocking and plumbing fixtures that may affect installation of compartments. Report any discrepancies to the architect.
- B. Take complete and accurate measurements of complete toilet compartment locations.
- C. Start of work constitutes acceptance of job.

3.02 INSTALLATION

- A. Install compartments in a rigid, straight, plumb and level manner as shown on the shop drawings and manufacturer's installation instructions.
- B. All doors and panels to be mounted at 12" above the finished floor.
- C. Clearance at vertical edges of door shall be uniform top to bottom.
- D. No evidence of cutting, drilling and/or patching shall be visible on the finished work.
- E. Finished surfaces shall be cleaned after installation and be left free of all imperfections.

3.03 WARRANTY

- A. Global Partitions guarantees its color-thru phenolic units, properly maintained, against delamination, breakage or corrosion for 10 years from the date of receipt by the customer. If materials are found defective during that period for the reasons listed above, the material will be replaced free of charge. No credits or allowances will be issued for any labor or expenses relating to the replacement of components covered under the warranty plan. All such expenses are to be borne by the buyer.

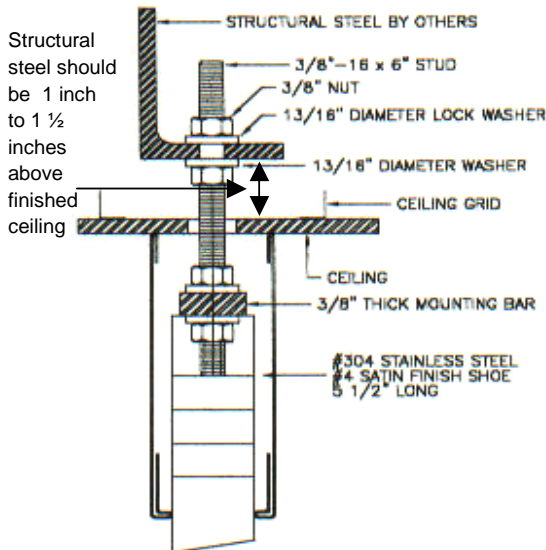
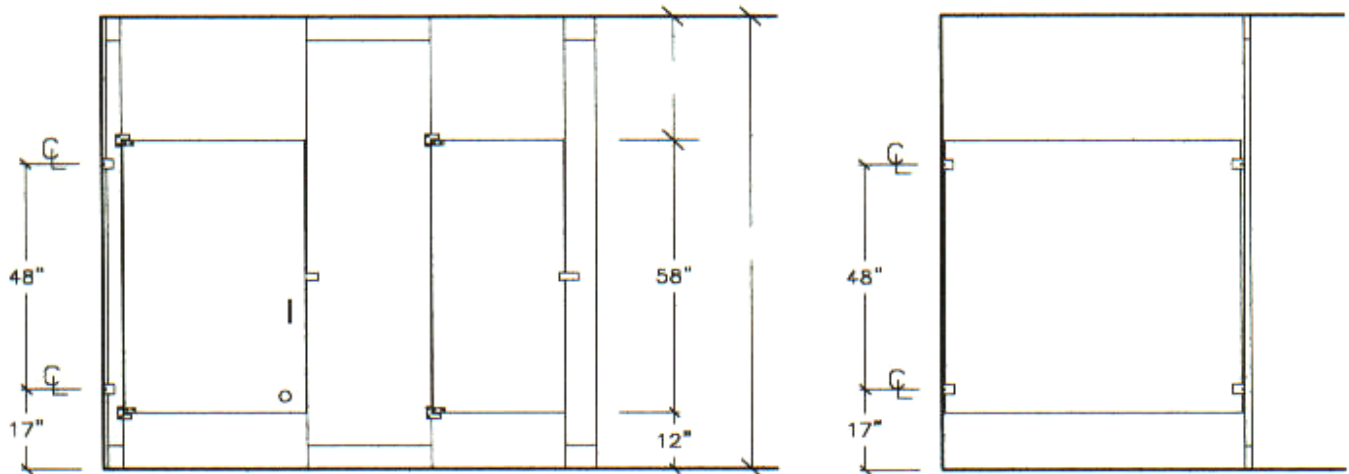

CEILING BOLT DETAIL

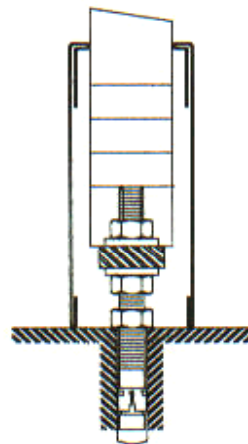

FLOOR ANCHOR DETAIL

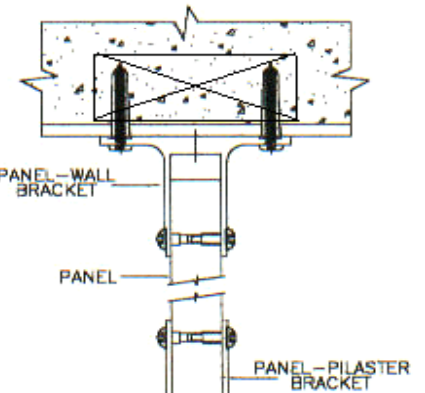

CROSS SECTION

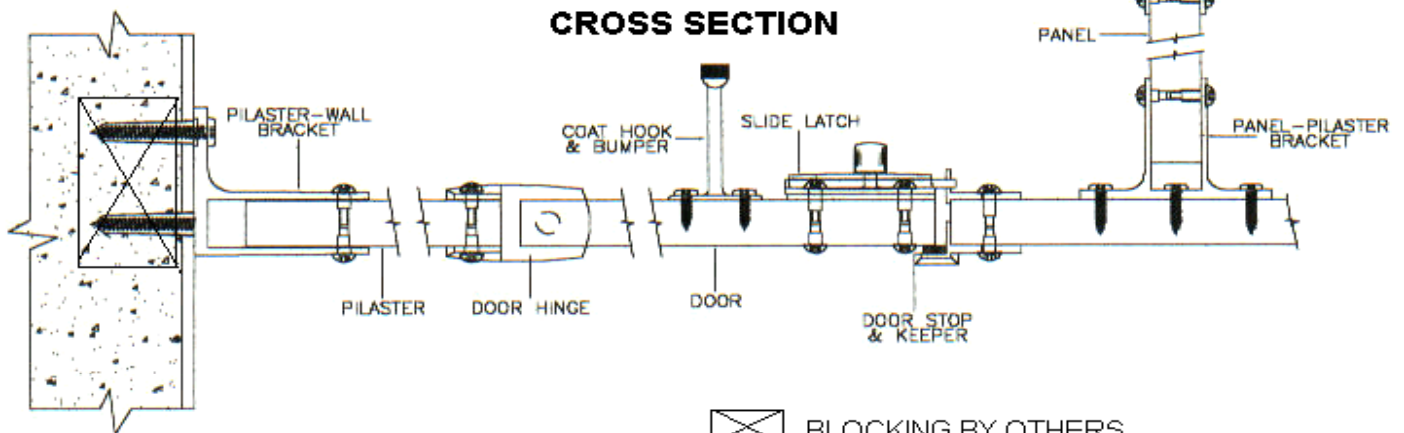

 BLOCKING BY OTHERS